

ALP/4500™

label printer/applicator

features & benefits

- **Modular Print Engine**, developed jointly by Diagraph and CAB, provides dependable plug-and-play flexibility. Windows drivers readily available.
- **Low Cost** of Diagraph engine is about half as much as standard OEM engines.
- **Choice** of either 203 or 300 dpi print heads.
- **Compact Unit** measures 27" x 22" x 17" with 12" OD supply.
- **Large Graphic Display** allows operators to easily navigate menus with the touch of a button. Diagnostic and Information Menus make the ALP/4500 the most self-sufficient printer/applicator on the market.
- **Reliable Sensing** provided by pressure/vacuum transducers that detect label presence and variable stroke distance to prevent mis-feeds and mis-labeled cartons. For optimum performance over time, the ALP/4500 auto-calibrates the transducers with every cycle.
- **Easy Maintenance** facilitated by print head and cover that open wide for cleaning.
- **Expansion Slots** for Discrete I/O and Ethernet cards to communicate status conditions to external devices.
- **Certified** by UL-60950, CE, CSA, FCC and ETL.

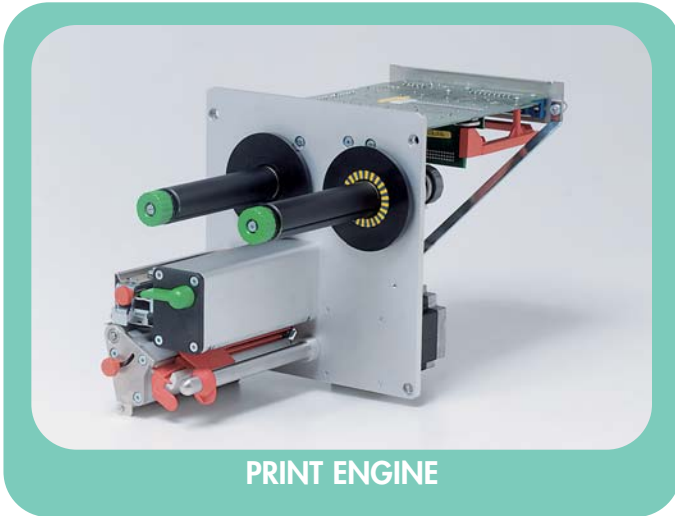

PRINT ENGINE

Design that's so advanced, it's simple!

As a print-and-apply system, it handles up to 55 products per minute on your production line, printing and applying labels with variable information, alphanumerics, graphics and bar codes.

You can transform it into a high-speed (1800 ipm) label applicator by simply plugging in a new module. This innovative system is incredibly simple to operate because of the graphics-based user interface. And it's easy to maintain because of the modular design.

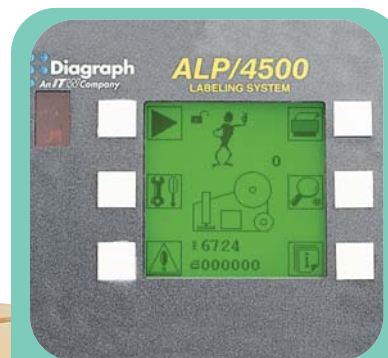

HANDHELD USER INTERFACE is easy for operators to use because it is primarily graphic based.

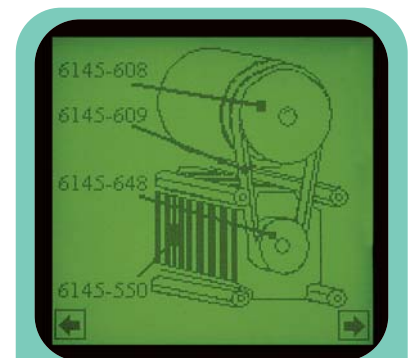

INFORMATION MENU offers images of ALP/4500 sub-assemblies. Providing part numbers assists maintenance personnel in re-ordering parts.



Finally, a system that's right for today and tomorrow.

3000 DIP 0

The superiority of the ALP/4500 is its simplicity. Simple installation. Simple set-ups. Simple operation. Simple changeovers. It's simply the best labeling system you can buy!

The modular Diagraph ALP/4500 system was developed to grow with your needs. It's a great print-and-apply system for many packaging applications. As new modules are introduced, it can also function as a high-volume label applicator.

Unwind Assembly. Free-float condition reduces stress on print module, thus increasing life and print quality. Dancer arm and band-brake eliminate over-feed.

Rewind Assembly. The dancer arm and stepper motor provide consistent web-tension, ensuring bar code and text quality. Minimal parts reduce wear points.

User Interface. The tethered interface can be mounted where it is most convenient for the operator. The single interface controls the settings for the print module, eliminating DIP switches and the need to learn a second interface, which is common with other OEM engines.

Print Engine Assembly. Offered in 203 or 300 dpi, the A3 print module is easy to maintain. The unit contains 8 Mb RAM and 1 Mb of non-volatile memory and offers 4.1" maximum print width. Print head can be replaced by removing only 1 fastener. Drive roller can be removed for cleaning or replaced by simply loosening 3 screws.

Tamp Cylinder Assembly. Features single-rod, non-rotating design. Cylinder home sensor monitors position; pressure/vacuum transducers (patent pending) monitor label presence on tamp pad, and tamp pad contact with product. This design assures label adhesion and prevents mis-feeds.

For more information on all Diagraph products, complete specifications, labeling consumables and service, please visit our website:

www.diagraph.com

 **Diagraph**
An **TW** Company

1 Missouri Research Park Drive • St. Charles, MO 63304 • Phone: 800-722-1125 • Fax: 636-300-2004
Equipment Sales: 800-722-1125 • Service, Parts & Inks: 800-526-2531 • Labeling Consumables: 800-695-0036

© 2002 Diagraph • Printed in U.S.A. • CQ • 7/02 • 10M

