

CVC330 Vial & Ampoule Wrap Labeler

- Lower Operating Costs

- Increase Operating Flexibility

- Unparalleled Service

- Quality that your Customers Demand



The CVC330 Vial & Ampoule Wrap Labeler is built to automatically apply *pressure sensitive* labels onto small diameter round containers. The 330 comes standard with a 700mm loading turn table, a ground chain conveyor, and modified railing for precise labeling of small vials and bottles. The 330 is an ideal machine for contract packagers and manufacturers serving the biotech, nutraceutical, pharmaceutical, and food markets.

All CVC labelers include our patented **Self Set™** software which utilizes a high frequency encoder for extremely easy setup and wrinkle free labeling at the touch of a button.

Labelers

Solid Dose Bottling Lines
Blister Packaging
Cartoning

"Leading Global Equipment Supplier"

www.cvcusa.com



CVC Technologies, Inc.

CVC330 Technical Specifications

Standard Features:

- Self Set Auto Adjusting Control System
- Stainless Steel Frame on lockable casters
- Stainless Steel flat bed conveyor with 4" wide table top ground down chain
- 25-Key Hand Held Terminal with LCD Display
- Label head with up to $\pm 1/32$ " accuracy and Integrated Wrap Station
- 700mm Loading Turn Table
- Custom railing for handling of small diameter products
- Label Sensor for Paper or Opaque Labels
- Product Sensor with Opaque and Clear Bottle Mode
- Variable Speed Separator Wheel
- Capacity up to 190 bottles per minute (BPM)
- ISO 9001:2000 Certified

Container Specifications:

- Bottle Height: 1" up to 10" (25mm - 254mm)
- Bottle Diameter: 1/2" to 4" (13mm - 102mm)

Label Specifications:

- Label Width/Height: 3/8" to 4-3/4" (10mm - 121mm)
- Label Length: 5/8" to 10" (16mm - 254mm)
- Label Roll: max 14" (356mm) outside diameter with 3" core
- Label Head Dispense Speed: Maximum 38 Meters/Min.

Machine Specifications:

- Conveyor Width: Standard 4"
- Conveyor Length: Standard 82"
- Conveyor Bed Height: Standard 36" (± 2 ")
- Machine Weight: 219kg (483lbs)

Air/Electrical Requirements:

- Power: 110V, Single Phase, 6 AMP
(208V Available on Request)
- Air: 4 cfm (only required when using Lot/Date Printer)

Available Options:

Printing:

- Hot Stamp (Lot/Date Coding)
Print Area: 2-3/4"(70mm)W x 2-1/2"(65mm)H
Type Sizes: 1.5mm, 2.0mm, or 2.5mm
Chase Size: 6 Lines of 13-22 Characters each
Low Ribbon Sensor
- Integrated Thermal Encoder (Lot/Date, Bar Code and Graphics)

Assemblies:

- Adjustable Tilt for Tapered Bottles
- Feed Screw
- Collecting Turn Table
- Infeed and Outfeed Conveyor Extensions
- Custom Wrap Belts
- Clear Label Sensor
- Product Infeed Tray with Stainless Steel Insert and Paddle for easy product loading
- Outfeed Collection Tray
- Low Label Sensor (Factory Installed Only)

Machine Layouts:

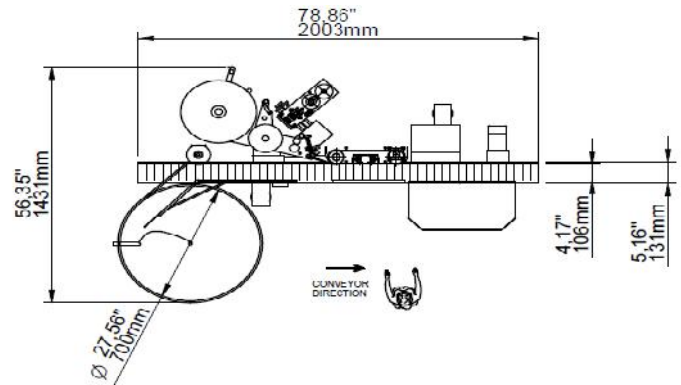

Top View

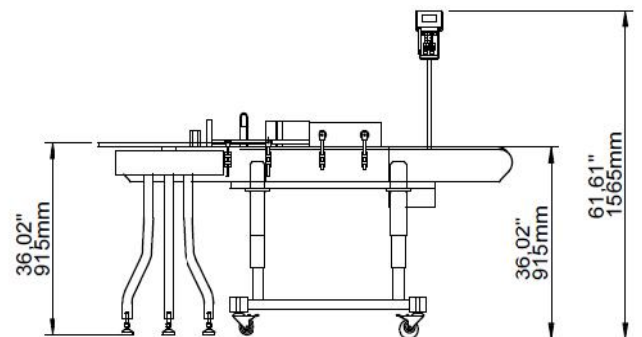

Front View



Quality • Value • Service

Authorized CVC Dealer

Copyright © CVC Technologies, Inc. • Jan. 2012 Edition

Dimensions shown are for standard machine. Conveyor can be extended or length may vary based on options selected. This labeler can run independently or be integrated into an automated packaging line.