

# CVC300 Wrap Labeler

- Lower Operating Costs

- Increase Operating Flexibility

- Unparalleled Service

- Quality that your Customers Demand



The CVC300 Wrap Labeler is built to automatically apply pressure sensitive labels onto round containers. It is an ideal machine for contract packagers and manufacturers serving the nutraceutical, food, cosmetic, personal care, and household product markets.

All CVC labelers include our patented **Self Set™** software which utilizes a high frequency encoder for extremely easy setup and wrinkle free labeling at the touch of a button.

## Labelers

Solid Dose Bottling Lines  
Blister Packaging  
Cartoning

"Leading Global Equipment Supplier"

[www.cvcusa.com](http://www.cvcusa.com)



**CVC Technologies, Inc.**

# CVC300 Technical Specifications

## Standard Features:

- Self Set Auto Adjusting Control System
- Stainless Steel Frame on lockable casters
- Stainless Steel flat bed conveyor with 4" wide table top chain (Raised Sanitary Bed)
- 25-Key Hand Held Terminal with LCD Display
- Label head with up to  $\pm 1/32$ " accuracy and Integrated Wrap Station
- Label Sensor for Paper or Opaque Labels
- Product Sensor with Opaque and Clear Bottle Mode
- Variable Speed Separator Wheel
- Capacity up to 170 bottles per minute (BPM)
- ISO 9001:2000 Certified

## Container Specifications:

- Bottle Height: 1" up to 12" (25mm - 305mm)
- Bottle Diameter: 1" to 7" (25mm - 178mm)  
(dependent on conveyor width)

## Label Specifications:

- Label Width/Height: 3/8" to 9" (10mm - 229mm)  
(dependent on labeling head type)
- Label Length: 5/8" to 12" (16mm - 305mm)
- Label Roll: max 14" (356mm) outside diameter with 3" core
- Label Head Dispense Speed: Maximum 38 Meters/Min.

## Machine Specifications:

- Conveyor Width: Standard 4", available in 4-1/2" and 6"
- Conveyor Length: Standard 79", available in 94" (sanitary)
- Conveyor Bed Height: Standard 36" ( $\pm 2$ ")
- Machine Weight: 180kg

## Air/Electrical Requirements:

- Power: 110V, Single Phase, 6 AMP  
(208V Available on Request)
- Air: 4 cfm (only required when using Lot/Date Printer)

## Available Options:

### Printing:

- Hot Stamp (Lot/Date Coding)  
Print Area: 2-3/4"(70mm)W x 2-1/2"(65mm)H  
Type Sizes: 1.5mm, 2.0mm, or 2.5mm  
Chase Size: 6 Lines of 13-22 Characters each  
Low Ribbon Sensor
- Integrated Thermal Encoder (Lot/Date, Bar Code and Graphics)

### Assemblies:

- Adjustable Tilt for Tapered Bottles
- Feed Screw
- Loading and Collecting Turn Tables
- Infeed and Outfeed Conveyor Extensions
- Custom Wrap Belts
- Clear Label Sensor
- Low Label Sensor (Factory Installed Only)
- Raised Sanitary Bed Conveyor

## Machine Layouts:

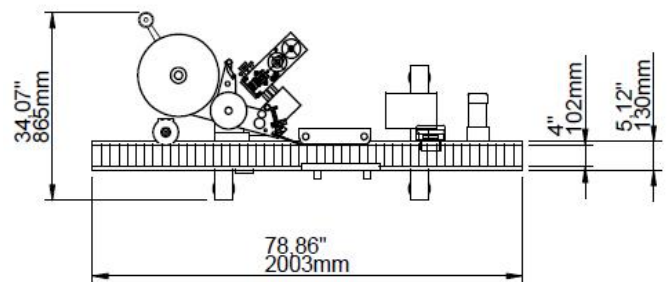

Top View

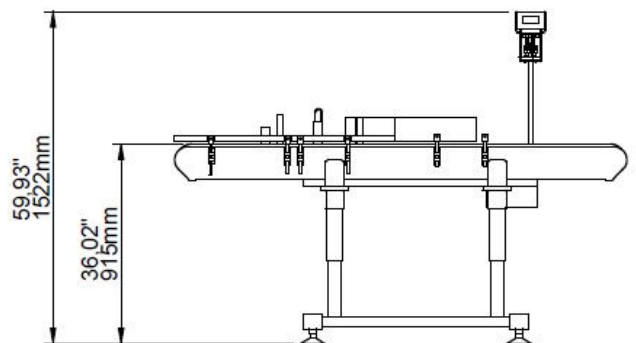

Front View

*Dimensions shown are for standard machine. Conveyor can be extended or length may vary based on options selected. This labeler can run independently or be integrated into an automated packaging line.*



Quality • Value • Service

Authorized CVC Dealer

**Westmark Industries, Inc.**  
6701 SW McEwan Road  
Lake Oswego, OR 97035-7815  
Phone: 1-800-275-2228  
Fax: 1-800-303-7491  
www.westmarkind.com

Copyright © CVC Technologies, Inc. • Jan. 2012 Edition