

VERSAPPLY® SERIES

Print-Apply Labeling Systems

The **VERSAPPLY® 9284 Series** of Print-Apply Labeling Systems are another set of cutting-edge product identification solutions from **code-in-motion®**.

For more than 25 years, **Versapply®** Labeling Equipment has been the industry standard for **Innovation, Quality and Reliability**. The first **VERSAPPLY®** Design Team created a trend sending adaptation of Thermal-Transfer and Direct-Thermo applications for the Packaging Industry. Starting with the most innovative printer of its time, the **FARGO** table top thermal-transfer printer, subsequent **VERSAPPLY®** print-apply designs progressed to include first generations of various Print Engines including early developments from **SATO**, followed by the introduction of **Zebra PAX** and **Datamax** Print Engines. These achievements have evolved through an intimate Research & Development relationship with print engine manufacturers.

By combining lessons learned from a multitude of global implementations, regular customer feedback and continuous **Versapply®** design enhancements, the ultimate dedicated and on-demand print-apply solution has been achieved. **Versapply® Print-Apply Labeling Systems** are the most compact, trusted and advanced print-apply labeling solution on the market today; the ideal union between accuracy, reliability and efficient label application.

Coupled with the most innovative and industry-proven application modules, **code-in-motion®** offers print and apply abilities across a variety of industries; labeling small medical and electrical components as well as corrugated cartons, stacked pallets and virtually any product in between.

What differentiates **Versapply®** systems from others are the various advanced technologies brought together into a seamless, high-performance solution.

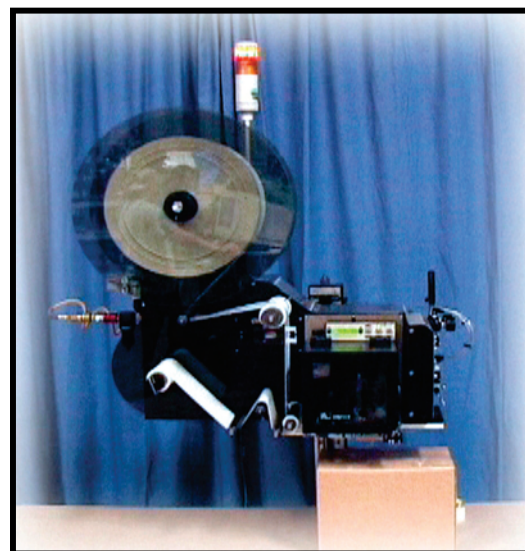

Each Print-Apply Labeling System can be configured with specific components, creating the perfect product identification solution for each individual customer:

Highlights, Features and Options:

- Size** - Perhaps the most compact Print-Apply Labeling System on the market.
- Quality** - All systems are configured with Anodized Aluminum and Stainless Steel manufactured components, and the highest quality purchased devices.
- Print Engine** - Engines from all the leading printer manufacturers (Zebra, Sato, Datamax...)
- Right or Left Hand** - Systems designed for interchangeability; "Never get stuck with obsolete and unusable equipment".
- Width** - Accommodates up to 7" label width.
- Unwind-Rewind** - Oversized, Powered and Un-powered unwind and rewind options.
- Control System and Interface** - Easy, adaptable and upgradeable, without proprietary components. "Don't be locked into a single supplier".



APPLICABLE
END EFFECTORS:

PATENTED
"TOUCH & GO"

WIPE-ON

TAMP

TAMP-BLOW

AIR-BLOW

FREE-AIR-VAC

GIMBAL-TAMP

VARIABLE
STROKE

SWING-TAMP



Print-Apply Labeling Systems

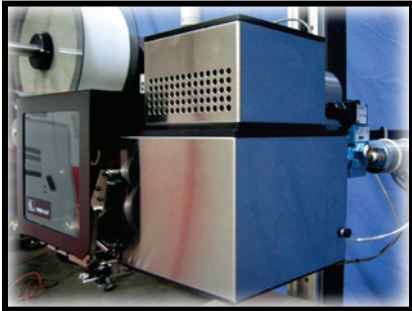
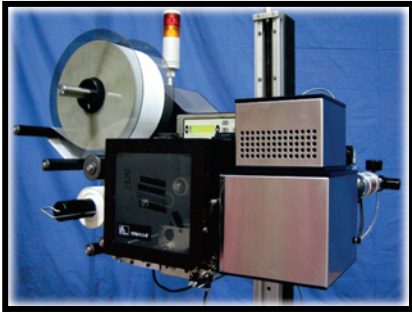

□ End Effectors:

Available in various standard offerings to very UNIQUE **code-in-motion® EXCLUSIVE** application methods:

- **Wipe-ON**
- **Tamp**
- **Tamp-Blow**
- **Air-Blow**
- **Free-Air-Vacuum**
- **Gimbal-Tamp**
- **Swing-Tamp**
- **"Touch & Go" Patented Technology**

Provides an ideal environment for unrestricted speed matching between the passing product and label to be applied. As a by-product, this exclusive technique allows **code-in-motion®** to offer the additional ability to inspect printed information via a Vision System or barcode scanners in a first-out condition...not available from any other equipment manufacturer.

Basic Technical Specifications

Overall Dimensions:

Length = 30"
Width = 18"
Height = 20"
Weight = 120 lbs.

Electrical (std):

120 VAC - 5Amp - 1ph

Air (std):

3CFM @ 120PSI

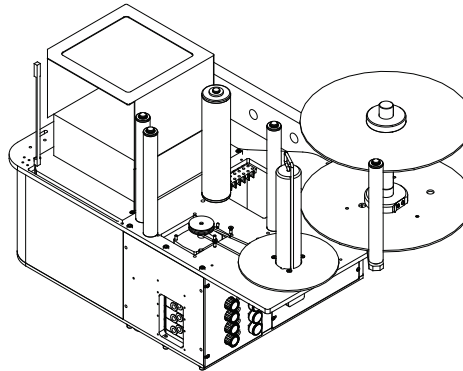

Comprehensive System Manuals describe in detail system operations and features through step-by-step descriptive text coupled with screen shots, photographs and process flows. This high quality, easy-to-use documentation serves operators, maintenance and engineering, and also greatly aids the writing of customer specific procedures.

Versapply® Print-Apply Labeling Systems are a capable and affordable solution for organizations looking for process improvements and increased productivity. These systems, as well as all other products and services by **code-in-motion®** are backed by the legendary **code-in-motion®** level of quality, reliability and exceptional customer service and support; providing an excellent return on investment for companies of all sizes.

§ § §

code-in-motion LLC, the leader in product identification and automation systems, offers innovative, integrated systems of superior design, performance and reliability. For information regarding our extended product range or any additional information regarding Print-Apply and related Product Handling systems, please contact us directly or visit our web site.

Contact Information:

code-in-motion LLC
232 Avenida Fabricante, Suite 103
San Clemente CA 92672
(p) 949.361.CODE (2633)
(f) 949.361.2636
www.code-in-motion.com

Represented by:



zebra



datamax



sato



code-in-motion

