

Model 314 DAT

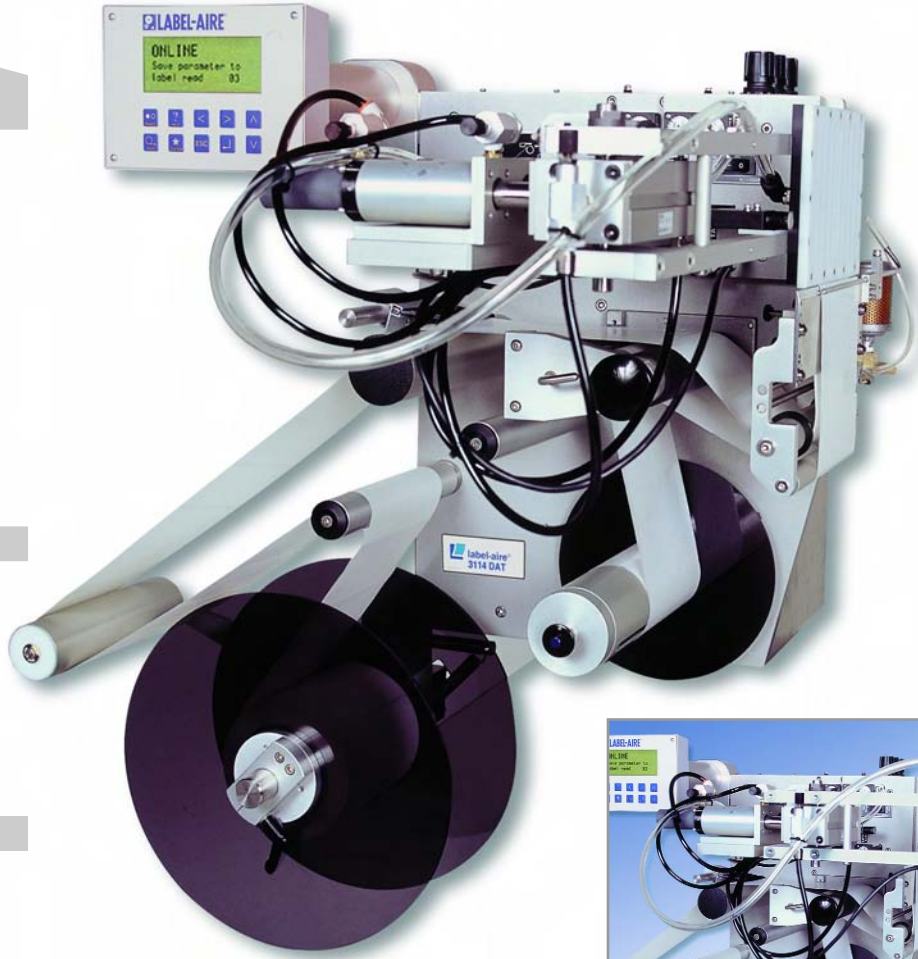

314 DAT shown in nose-up position.

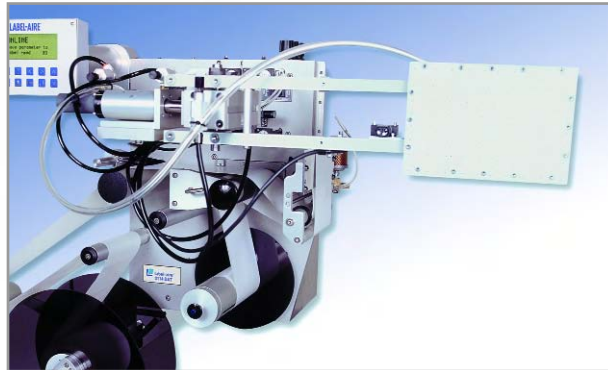

314 Dual Action Tamp

Primary Applicator

DAT

3114 Dual Action Tamp Primary Applicator Specifications

The Label-Aire® Model 3114 Dual Action Tamp (DAT) Primary Applicator makes dual panel labeling even easier.

The NEW Label-Aire Model 3114 represents the ultimate in dual action tamp pressure-sensitive labeling technology.

The Model 3114 Dual Action Tamp labeler is simply the most advanced two-panel labeler on the market with its intelligent controller, impressive speeds, and high accuracy.

The user-friendly 3114 Dual Action Tamp features Automatic label setup, Quick-Action collapsible rewind, and a large R3 digital display that is Rotateable, Remoteable, and very Readable. Adding to its versatility, the 3114 Dual Action Tamp can be oriented nose-up, nose-down or reels-up. With five onboard user-selectable languages, domestic or CE (European) configurations, and standard/metric unit display, the 3114 Dual Action Tamp can handle almost any PS labeling application on the planet.

3114 DAT Advanced Features	
Automatic setup	Includes multiple programmable label pages for easy change-overs to different label sizes.
R3 digital display	With five languages (English, French, German, Italian, Spanish) and detailed alarm message.
Quick-Action collapsible rewind	For easy removal of scrap liner.
Optional smart powered rewind	For improved label accuracy and dynamic web tension control.



Headquarters
550 Burning Tree Road
Fullerton, CA 92833 USA

☎ 714.441.0700
 📠 714.526.0300
 📧 info@label-aire.com
 🌐 www.label-aire.com

Europe
Sjællandsvej 27A
DK-9500 Hobro, Denmark

☎ +45 9657 0063
 📠 +45 9657 0064
 📧 info@label-aire.eu
 🌐 www.label-aire.eu

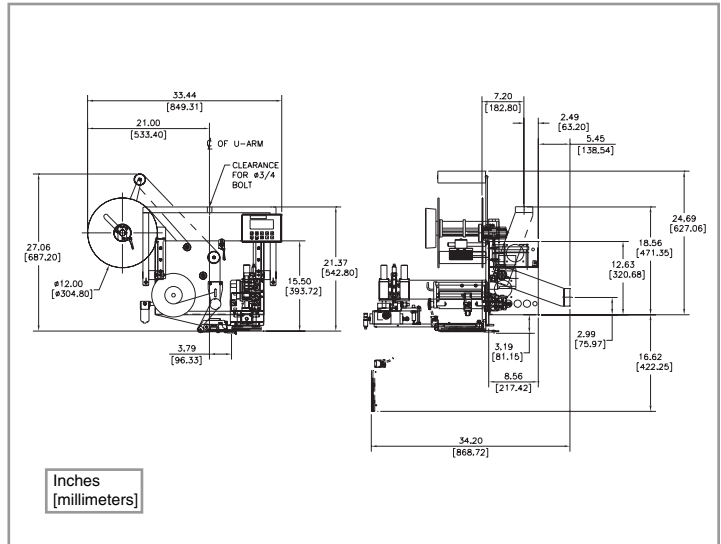

Dimensions:

Height: 27" (685.5 mm)
 Length: 33.44" (849.3 mm)
 Width: 34.2" (868.7 mm)

Weight:

140 lbs. (63.5 kg)

Standard Label Dimensions:

Max. Web Width: 4.13" (105 mm)
 Optional Label Width: 7.13" (181 mm)
 Min Web Width: .63" (16 mm)
 Min. Label Length: .38" (10 mm)

Label Packaging:

12" (305 mm) O.D. rolls std. on 3" (76 mm) I.D. cores
 Up to 16" (406 mm) rolls with optional 16" (406 mm) unwind

Dispense Speed:

Up to 1500" (3810 cm) of web per minute (standard)
 Up to 2000" (5080 cm) of web per minute with powered rewind

Label Placement Accuracy:

+/- 1/32" (.8 mm)

Electrical:

115 Volts AC 60 Hz 3 Amps.
 220 Volts AC 50 Hz optional.

Air:

4 cfm at 90 psi to 110 psi for most applications

Options:

16" (406 mm) non-powered unwind
 Smart 10" (254 mm) powered rewind
 6" (152 mm) label core adapter
 Strobe signals for "low label" and "out of labels"
Consult factory for additional options.

Distributed by:

Westmark Industries, Inc.
 6701 SW McEwan Rd.
 Lake Oswego, OR 97035-7815
 Phone: 1-800-275-2228
 Fax: 1-800-303-7491
 www.westmarkind.com